

Oil / Air Cooling Units

for mechanical engineering and mobile hydraulics



With partnership into the future

FUNKE is a leader in the development and production of quality heat exchangers with a heat transfer area of up to 2400 m². The range of products comprises shell-and-tube heat exchangers, bolted and brazed plate heat exchangers as well as oil/air cooling units and electrical oil pre-heaters. Thus, as one of the few producers worldwide, FUNKE offers solutions with optimum thermodynamic designs for different industries and virtually all applications.

FUNKE focuses on customer orientation, highest quality standards, flexibility and advisory skills – important benefits a company of just the right size is able to offer.



FUNKE oil/air cooling units are based on the system Längerer & Reich. The consequent development of this system by FUNKE resulted in up to now 17 OKAN standard sizes in one or multi-pass design with a maximum heat dissipation of 6,2 kW/K, all available in line with the demand of the respective application. This wide variety of standard units allows for flexible serving most of the applications. For plant engineering and series producers regularly project-specific special constructions are developed.

Applications

- cooling of oils, hydraulic fluids and emulsions using a stream of ambient air, especially in the field of mechanical engineering, plant engineering, building machinery and special vehicle construction
- usage as supporting cooler when peak loads are reached (e.g. summer)
- when water is not or only very limited available

Advantages of FUNKE OKAN series

- strikingly lower costs per kW heat dissipation
- robust, compact design matching highest quality standards
- customer-specific designs feasible
- low costs for installation and operation
- variable installation position
- long service-life
- virtually maintenance-free



Sea air resistant surface coating,
e.g. for use in shipbuilding



Application examples



Cooling unit
turbo-coupling, Voith



PistenBully, Kässbohrer



Truck mixer, Liebherr



Sugar-beet
harvester,
Holmer



Oil supply
system,
Schnupp



Mobile deep
drill rigs,
Hütte & Co.

Design and function

Basic element is an aluminium cooler in bar and plate construction. The oil tubes are fitted with turbulence elements to guarantee an optimum heat transfer. Depending on the volumetric flow rate, the medium to be cooled flows through the cooler either in one pass or multiple passes and is cooled by the stream of ambient air produced by the fan. The fan is mounted behind the cooler so that the standard fan mode of operation is suction, which means that the cooling air streams from the cooler towards the motor. The fan can also be supplied in pressure mode, if so specified upon ordering. The oil and air fins, fan blades and motor power are carefully engineered and dimensioned to achieve an optimum degree of heat dissipation.

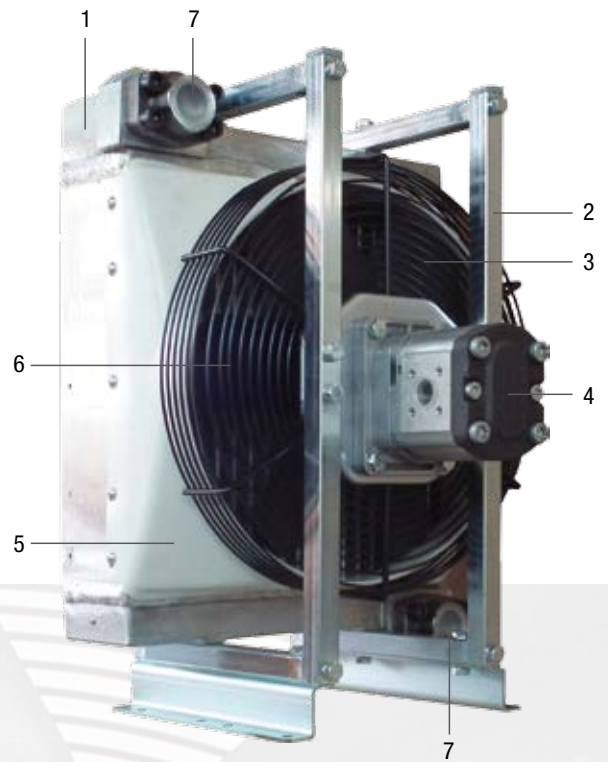

- | | |
|---------------------------------------|------------------------|
| 1 Cooler | 2 Support brackets |
| 1.1 Tank | 3 Fan guard |
| 1.2 Turbulence elements
(oil fins) | 4 Motor |
| 1.3 Air fins | 5 Fan shroud |
| 1.4 Side wall | 6 High-performance fan |
| | 7 SAE counter flange |

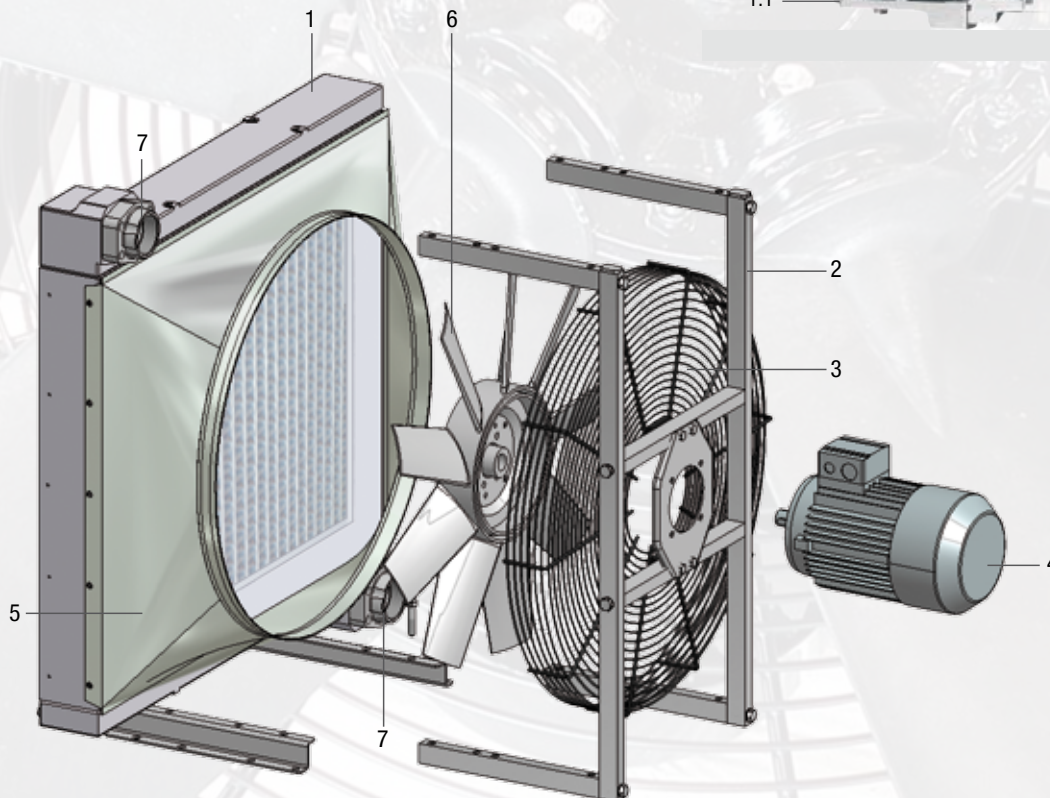
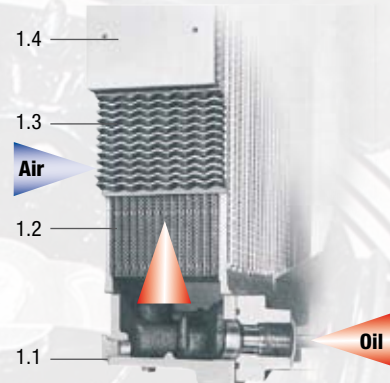

Nomenclature of cooler core

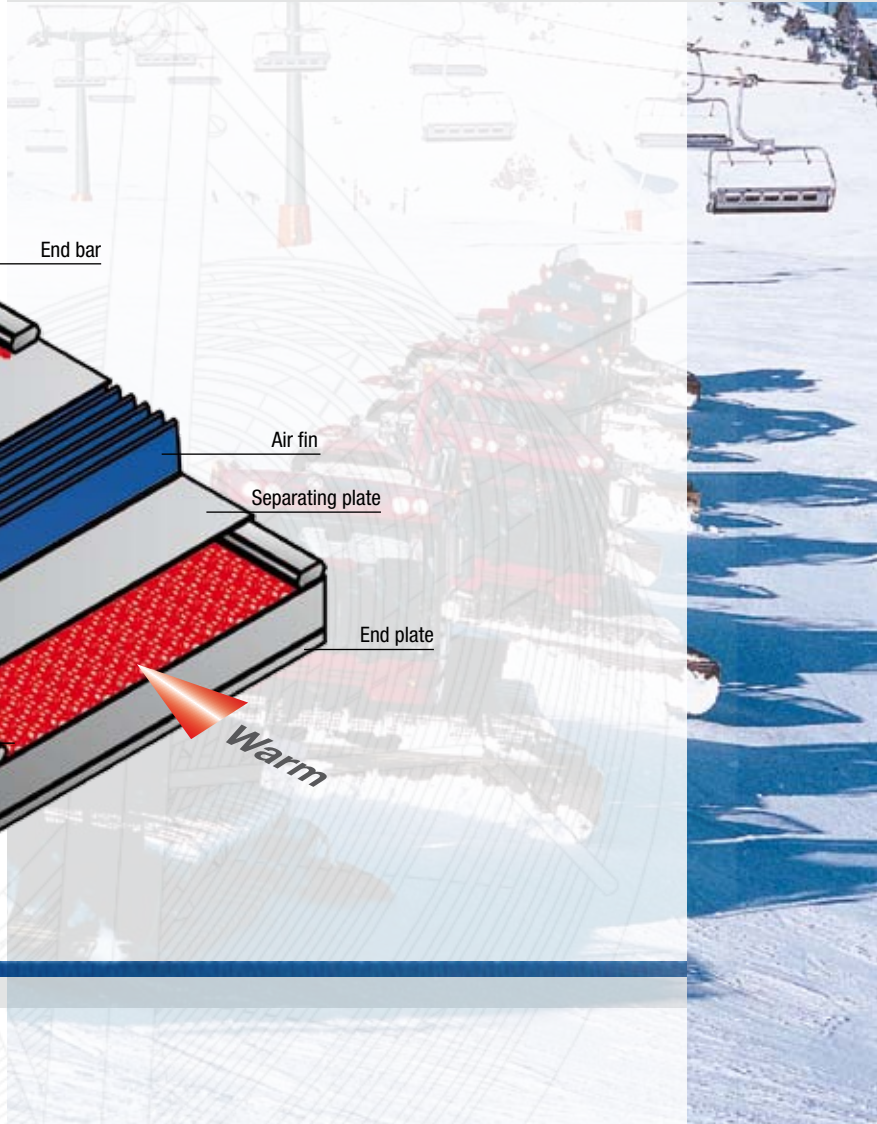
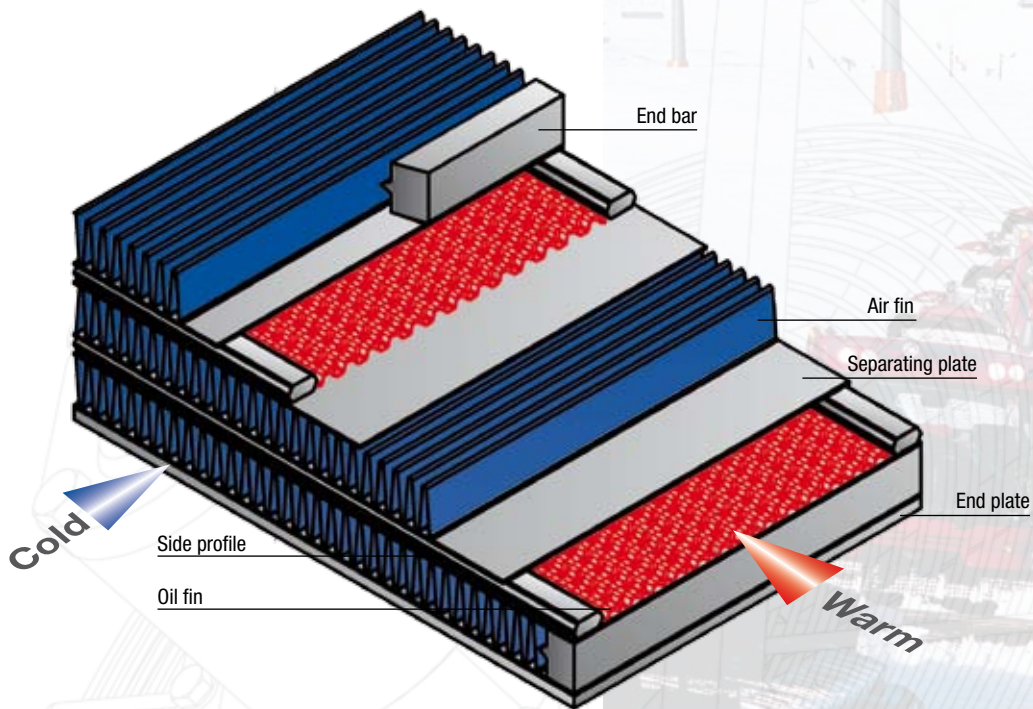

Operating data

17 sizes

Max. heat dissipation:	6.2 kW/K
Max. operating pressure:	26 bar possible
Max. operating temperature:	for oil 120 °C for emulsions 90 °C
Standard ambient temperatures:	-20 °C to + 40 °C
Frontal areas of cooler core:	0.05 to 1.44 m ²
Fan drives:	AC-motor DC-motor Hydraulic motor

Optional equipment

- System with pump
- Explosion protected execution
- Sea air resistant surface protection
- Air filter for cooler core

Technical Data – Series “OKAN II”

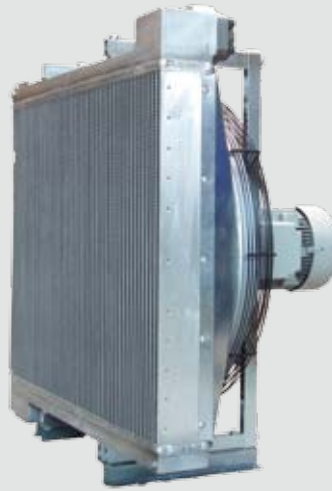
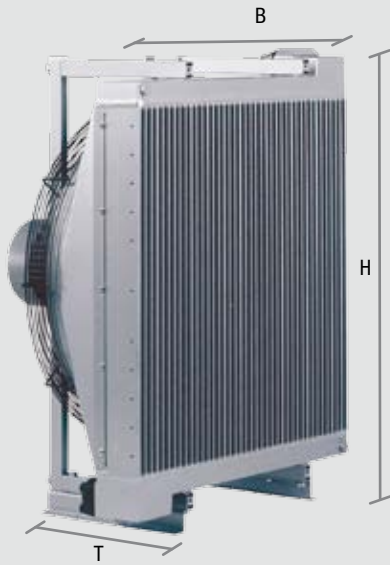

Model with AC-motor



Model with hydraulic motor

13 sizes in frame construction for all common applications

Size		02	03	04	05	06	07	08	09	10	11	13	14	15
Cooler core (m ²)		0.050	0.080	0.100	0.160	0.200	0.250	0.315	0.400	0.500	0.600	0.800	1.000	1.44
Weight ≈ (kg)		16	23	25	35	38	46	51	68	78	138	177	189	300
Dimensions ≈ (mm)	B	295	350	350	455	455	550	550	660	820	820	970	970	1286
	H	380	440	510	610	710	720	850	850	870	1020	1170	1360	1520
	T	425	470	470	540	540	575	575	635	635	710	810	810	800
Noise level 1m/7m (dB(A))	750 min ⁻¹	-	-	-	57/45	58/46	62/50	66/54	75/63	74/62	76/64	79/67	79/67	88/76
	1000 min ⁻¹	-	59/47	59/47	64/52	65/53	70/58	72/60	80/68	80/68	82/70	85/73	86/74	95/83
	1500 min ⁻¹	61/49	70/58	70/58	75/63	75/63	82/70	81/69	90/78	91/79	92/80	92/80	95/83	99/87
	3000 min ⁻¹	79/67	84/72	84/72	-	-	-	-	-	-	-	-	-	-

Calculation of specific heat dissipation

$$P_{01} = \frac{P_V}{t_{Oil} - t_{Al}} \quad (\text{kW/K})$$

Symbols:

P_{01} : Specific heat dissipation (kW/K)

P_{PI} : Power loss (kW)

t_{Oil} : Oil inlet temperature (°C)

t_{Al} : Air inlet temperature (°C)

V_{Oil} : Oil flow (l/min)

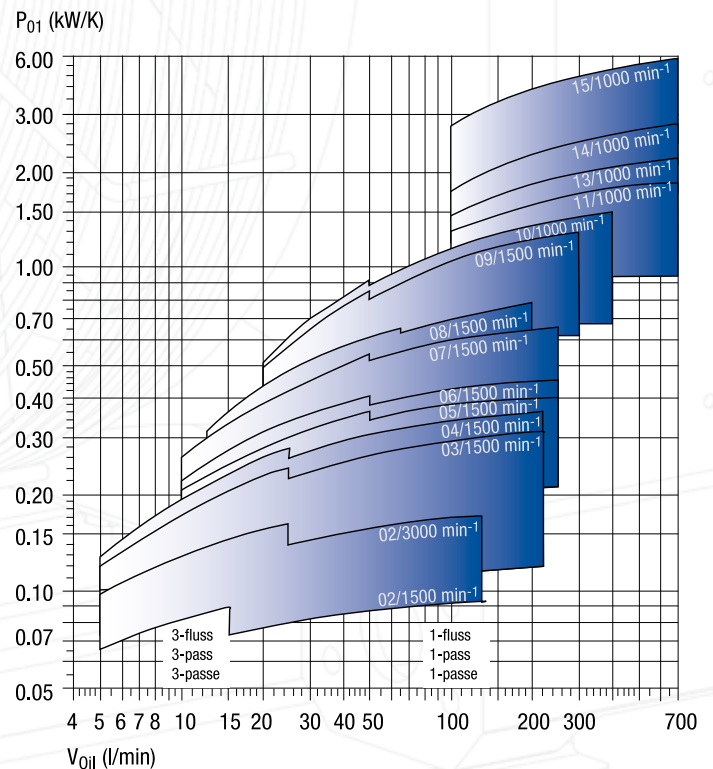

Technical data – Series “OKAN III”



AC-motor



DC-motor

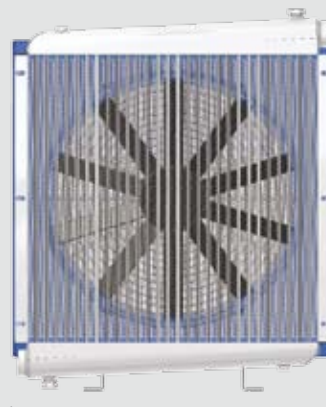

B



T

The series with 65 mm core depth, especially appropriate for mobile hydraulics

- OKAN III-units are characterized by their compact design at reduced weight
- When a DC-motor is applied an installation depth of less than 400 mm can be realized!

Size		III-1	III-2	III-3	III-4
Cooler core (m ²)		0.08	0.11	0.15	0.21
Weight ≈ (kg)		15	21	25	31
Dimensions ≈ (mm)	B	320	368	420	500
	H	423	475	543	608
	T	400	425	425	425
Noise level 1m/7m (dB(A))	1000 min ⁻¹	-	-	62/48	65/52
	1500 min ⁻¹	63/51	68/54	72/58	76/63
	3000 min ⁻¹	78/66	85/70	87/74	-

Tabular values apply for design with AC-motor

Calculation of specific heat dissipation

$$P_{01} = \frac{P_V}{t_{Oil1} - t_{Al}} \quad (\text{kW/K})$$

Symbols:

P_{01} : Specific heat dissipation (kW/K)

P_{PI} : Power loss (kW)

t_{Oil1} : Oil inlet temperature (°C)

t_{Al} : Air inlet temperature (°C)

V_{Oil} : Oil flow (l/min)

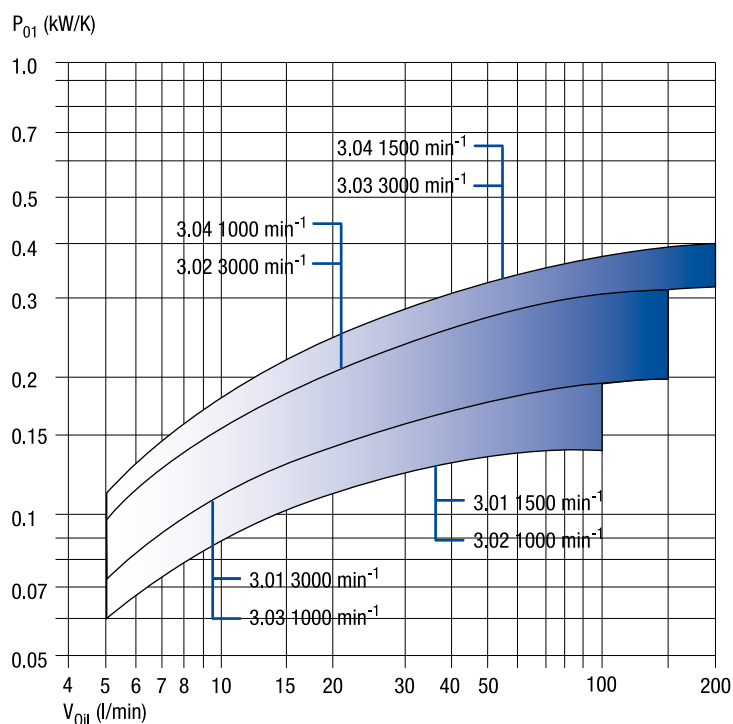



Quality means safety. Each unit built by FUNKE is design and pressure tested. Additional approvals are also available in accordance with quality authorities such as:

- American Bureau of Shipping (ABS)
- Bureau Veritas (BV)
- Det Norske Veritas (DNV)
- Germanischer Lloyd (GL)
- Lloyds Register of Shipping (LRS)
- Technischer Überwachungsverein (TÜV)

as well as customers' test and inspection regulations.

FUNKE has been certified according to DIN EN ISO 9001:2008, DIN EN ISO 14001:2004 and is an approved manufacturer according to:

- EU Pressure Equipment Directive 2014/68/EU (PED), Module H/H1
- HP0 in connection with DIN EN ISO 3834-2
- ASME U-Stamp & ASME R-Stamp
- Custom Union (TRTS 032/2013)
- China Certificate



FUNKE Wärmeaustauscher Apparatebau GmbH
Vertrieb SIP
Echterdinger Straße 111
70794 Filderstadt · Germany
T +49 (0) 711/707 082-0
F +49 (0) 711/707 082-19
info@funke.de
www.funke.de

Funke Wärmeaustauscher Apparatebau GmbH
Zur Dessel 1
31028 Gronau/Leine · Germany
T +49 (0) 51 82/582-0
F +49 (0) 51 82/582-48
info@funke.de
www.funke.de

